

view 1: Room A

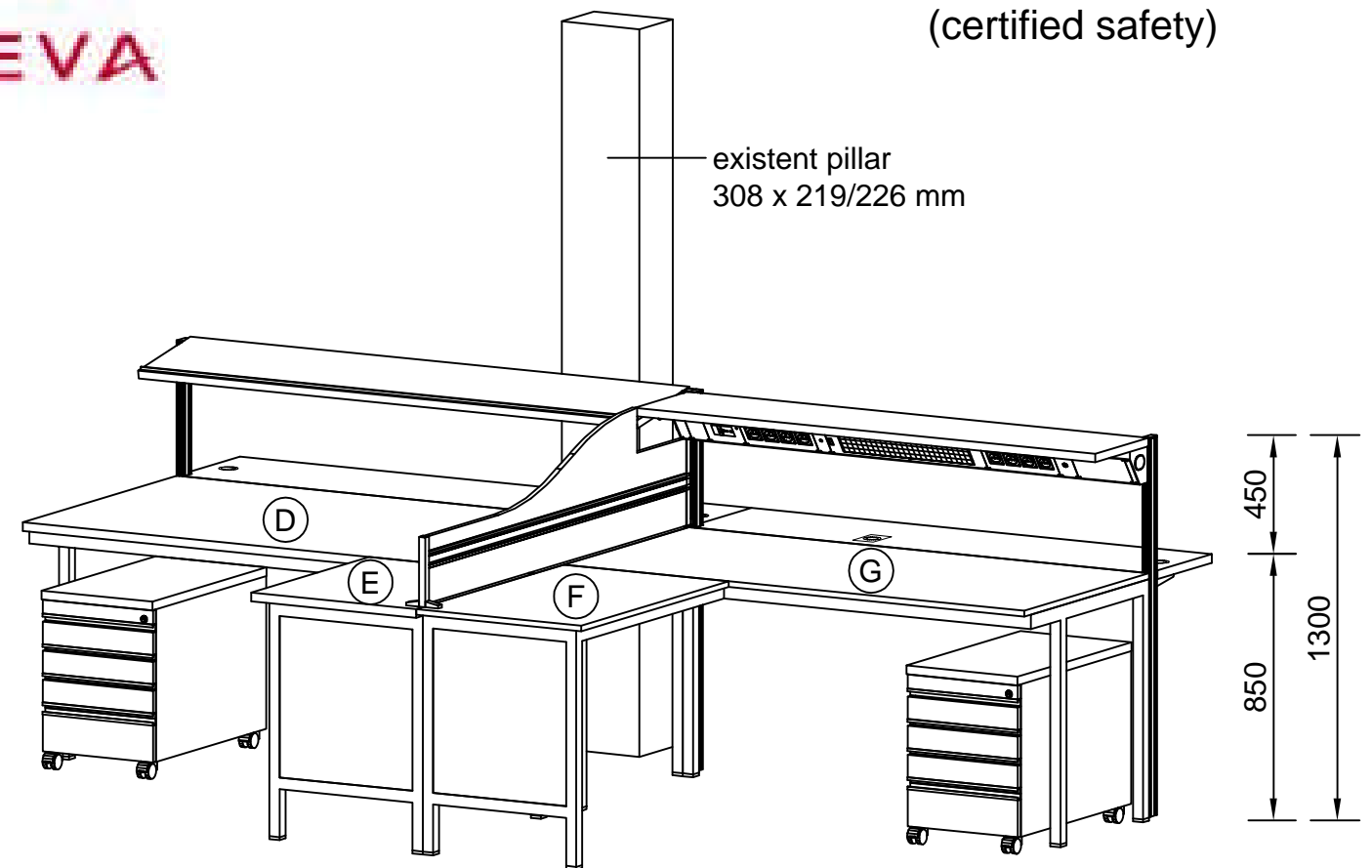

GS-certified laboratory system ABZ® (certified safety)

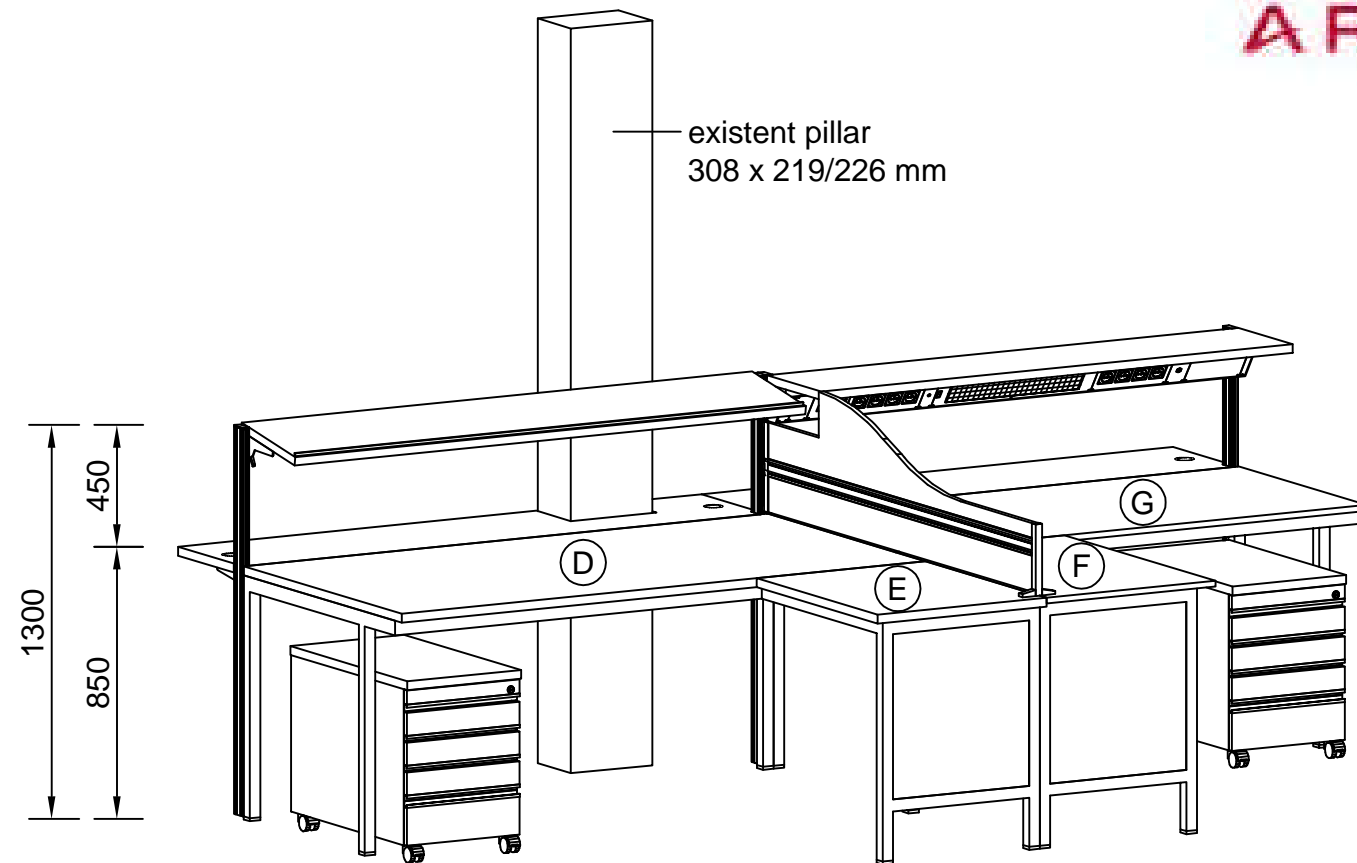

For these technical data all rights are reserved. Particularly duplications, utilization or notification of the contents to third persons are not allowed.

equipment of the system duct

M = 1:50

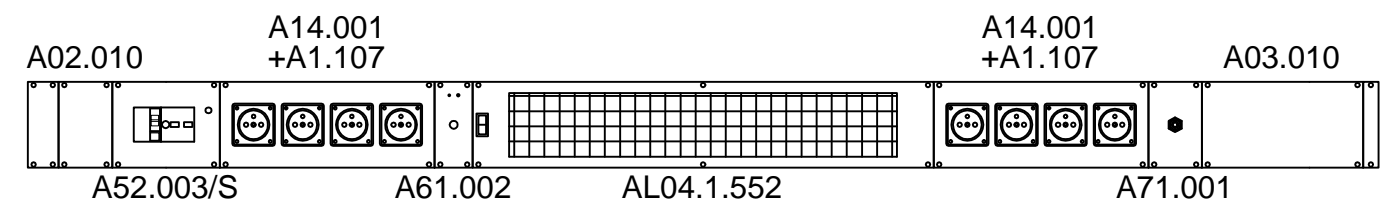
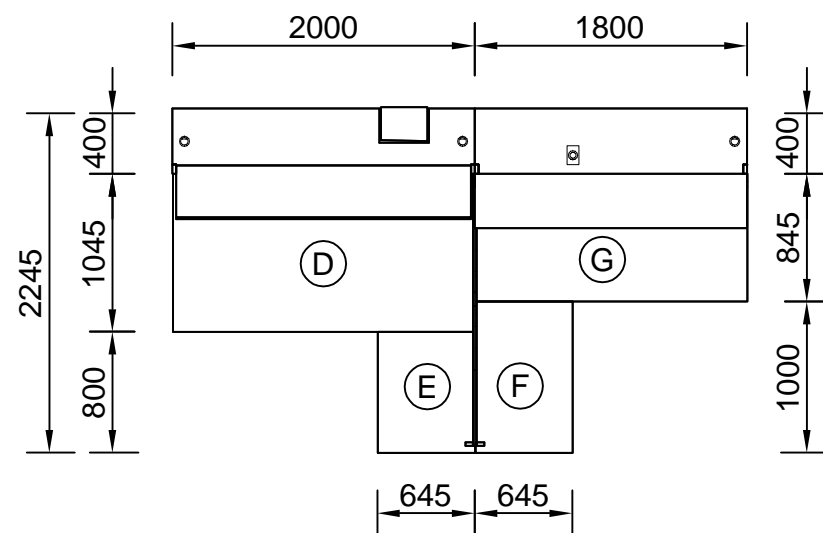

<p>Ernst Fischer GmbH & Co.KG Meß- und Prüfgeräte Labor- und Arbeitsplatz- systeme, Testsysteme. D-72250 Freudenstadt</p>	2007	Datum	Name	Maßstab	Freimaßtoleranzen nach DIN 7168 mittel	Änderungen	Nr.	Datum	Name
	Bearb.	16.05.	gs			like AG	-002	30.05.07	gs
	Gepr.					like KA		29.06.07	gs
	Norm					Für diese Unterlage behalten wir uns alle Rechte vor !			
	Angebots-Nr.	KA7038				Kunde:			
Benennung	view 1				Mobitest 8, rue Alfred de Vigny F 25000 Besancon				
Ersatz durch					Ersatz für				